

产品规格书

Product specification

锂电池主动均衡器

Lithium Battery Active Equalizer

JK-B15A24S

版本：V11.6.1

成都极空科技有限公司

Chengdu Jikong Technology Co.LTD

1. 产品概述(Product Overview) .....	4
1.1. 功能特性(Functional characteristics) .....	5
1.2. 结构框图(Structural block diagram) .....	6
2. 产品选型指南(Product selection guide) .....	7
2.1. 产品功能配置表(Product function configuration table) .....	7
2.2. 产品适配指南(Product adaptation guide) .....	8
2.3. 功能选配指南(Function selection guide) .....	8
3. 功能介绍及使用说明(Function introduction and usage instructions) .....	9
3.1. 主动均衡(Active equalization) .....	9
3.2. 通信功能(communication function) .....	9
4. 主要参数 (Main parameter) .....	10
4.1. 基本参数(Basic parameter) .....	10
4.2. 默认参数(Default parameters) .....	10
5. 接口定义(Interface definition) .....	11
5.1. 产品外形(Product Appearance) .....	11
5.2. 产品连接器、LED 定义(Product connector, LED definition) .....	12
5.3. 产品尺寸(Product size) .....	15
6. 安装方法 (Installation method) .....	16
6.1. 单个均衡器安装(Single Equalizer Installation) .....	16
6.2. 多个均衡器级联安装(Cascade installation of multiple equalizers) .....	18
7. 设备使用说明(APP operation Instructions) .....	19
7.1. APP 安装 (APP installation) .....	19
7.2. 设备激活(Device activation) .....	20
7.3. 参数设置(Parameter setting) .....	20

## 版本修改记录

修订日期	版本号	修订概要	作者
2024.03.22	V11.6.1	首次发布	张海艳

## 1. 产品概述(Product Overview)

电池主动均衡器是为大容量串联电池组量身打造的均衡管理系统。均衡器以超级电容为媒介，实现主动式能量转移均衡。

Battery Active-Balancer is a balanced management system tailored for large-capacity series battery packs. The Balancer USES ultracapacitors as the medium to balance the active energy transfer.

均衡器适用于 2~24 串的电池组，具备电压采集和均衡功能。均衡器工作时以持续 15A 的均衡电流进行能量转移，均衡电流不依赖电池组中串联 电池单体的压差。单体电压采集范围 1 V~5V，精度  $\pm 3\text{mV}$ 。可适用于磷酸铁锂、三元锂、钛酸、铅酸等市面上的所有电池种类。

The Balancer is suitable for 2 ~ 24 series battery packs, with the functions of voltage collection and balance. The balancer operates with a constant balance-current of 15A for energy transfer. The balance-current does not depend on the delta-voltage of the battery cells in series. Cell voltage acquisition range 1 V ~ 5V, accuracy  $\pm 3\text{mV}$ . Applicable to Li-ion, Lipo, Lifepo4, LTO and other battery on the market.

均衡器具备蓝牙通信功能，并配套手机 APP 软件。可以通过手机蓝牙连接均衡器以查看电池单体电压、均衡状态、修改参数等操作。均衡器体积小、易携带，可广泛应用于小型观光车、代步车、共享汽车、大功率储能、基站备用电源、太阳能电站等产品的电池 PACK 内，亦可用于电池均衡维修、修复等场合。

The balancer is equipped with bluetooth communication function and supports mobile APP software. The balancer can be connected to the phone via bluetooth to check the individual battery voltage, balance state, modify parameters and other operations. The balancer is small in size and easy to carry. It can be widely used in the battery PACK of small sightseeing car, scooter, sharing car, high-power energy storage, base station backup power supply, solar power station and other products. It can also be used in battery balance maintenance, repair and other occasions.

## 1.1. 功能特性(Functional characteristics)

- LED蓝牙状态指示
- APP蓝牙远程操作
- 高精度电压采集( $\pm 3\text{mV}$ )
- 主动均衡
- 支持选配RS485
- 支持选配CAN
- LED Bluetooth status indicator
- APP Bluetooth remote operation
- High precision voltage acquisition ( $\pm 3\text{mV}$ )
- Active equalization
- Support optional RS485
- Support optional CAN

## 1.2. 结构框图(Structural block diagram)

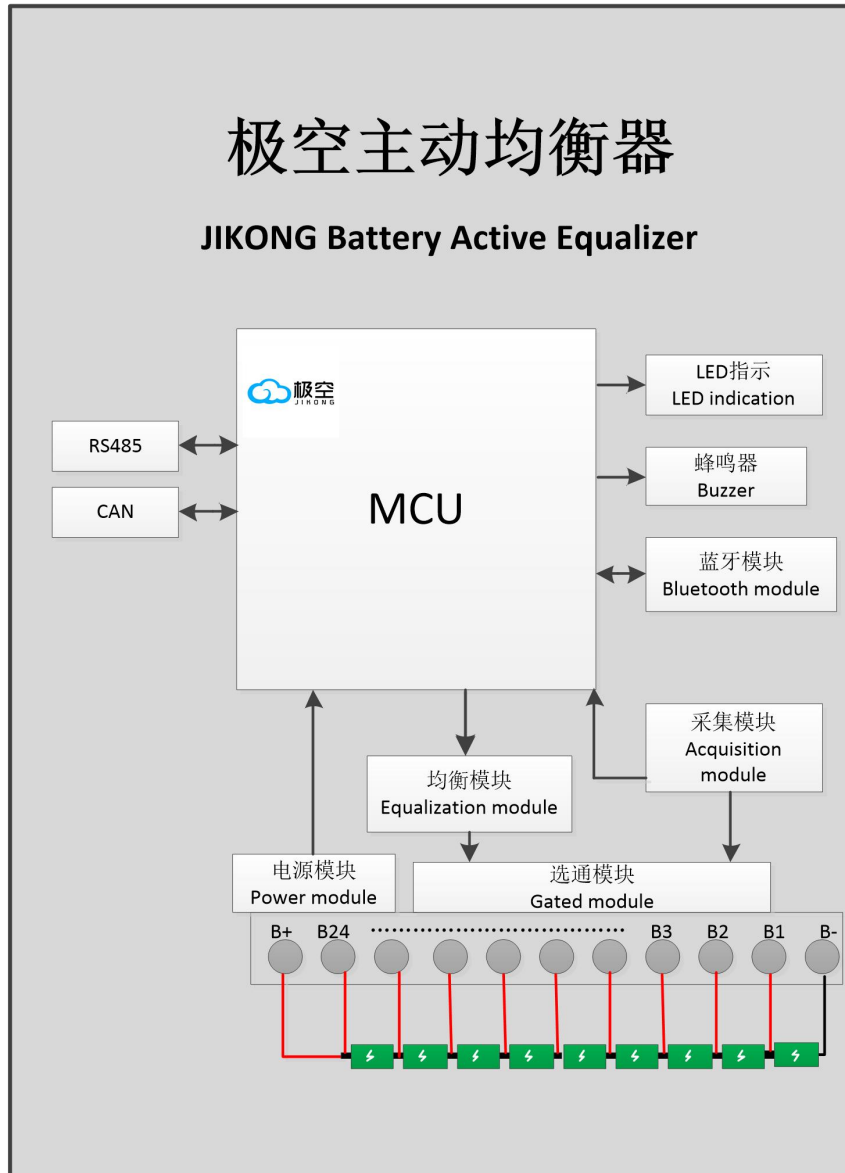

JK-B15A24S 结构框图

JK-B15A24S structure block diagram

## 2. 产品选型指南(Product selection guide)

### 2.1. 产品功能配置表(Product function configuration table)

产品规格 (Product specification)	JK-B15A24S	
序号 (Serial number)	功能 (Function)	配置 (Configuration)
1	主动均衡电流 (Active equalizing current)	15A
2	蓝牙功能 (Bluetooth function)	标配 (Standard option)
3	主动均衡 (Active equalization)	标配 (Standard option)
4	RS485	选配 (Optional)
5	CAN	选配 (Optional)

## 2.2. 产品适配指南(Product adaptation guide)

序号 (Serial number)	产品规格 (Product specification)	电池类型 (Battery type)	适配串数 (Number of adaptive battery strings)
1	JK-B15A24S	三元锂电池 (Ternary lithium battery)	2~24
		铁锂电池 (Lithium iron battery)	2~24
		钛酸锂电池 (Lithium titanate battery)	2~24

## 2.3. 功能选配指南(Function selection guide)

序号 (Serial number)	电池串数 (Battery string)	选配功能 (Optional function)	产品型号 (Product model)
1	2~24	标配 (Standard option)	<b>JK-B15A24S</b>

## 3. 功能介绍及使用说明(Function introduction and usage instructions)

### 3.1. 主动均衡(Active equalization)

主动均衡器采用主动均衡技术，均衡的原理是将高电压的电芯能量转移到低电压的电芯中，通过主动均衡器这一媒介实现能量转移。用户在使用均衡功能之前需要设置电池基本参数，需要下载极空BMS-APP，下载之后在极空APP中参数设置页面设置电池类型，默认参数见第四章。设置完成电池类型后在常用设置中设置电池基本参数，包括单体数量、电池容量、触发均衡压差(可保持默认)、电压校准、电流校准等。

用户可在APP的参数设置中自行设置均衡触发压差(mV)，均衡打开时，当电池包中任意两串电池压差大于设定值时均衡自动打开，压差小于设置值后关闭。默认均衡电流为最大值**15A**，用户可根据自己电池容量来调整，建议均衡电流不超过电池容量(C)的0.2C。如无需均衡功能，可在APP的BMS控制页中将均衡开关设置为关闭状态。

The active equalizer adopts active equalization technology, and the principle of equalization is to transfer the energy of the high-voltage cell to the low-voltage cell, and realize the energy transfer through the medium of the active equalizer. Before using the balancing function, users need to set the basic parameters of the battery and download the extreme space BMS-APP. After downloading, set the battery type on the parameter setting page of the extreme space APP. For default parameters, see Chapter 4. After setting the battery type, set basic battery parameters in common Settings, including the number of cells, battery capacity, trigger equalization differential pressure (the default value can be retained), voltage calibration, and current calibration.

Users can set the balance trigger pressure difference (mV) in the parameter setting of the APP. When the balance is turned on, the balance will be turned on automatically when the pressure difference of any two strings of batteries in the battery pack is greater than the set value, and the balance will be turned off when the pressure difference is less than the set value. The default balance current is 15A. Users can adjust the balance current according to their own battery capacity. It is recommended that the balance current not exceed 0.2C of the battery capacity (C). If you do not need the balancing function, you can set the balancing switch to off in the BMS control page of the APP.

### 3.2. 通信功能(communication function)

主动均衡器支持选配CAN/RS485功能，用户可以根据自身需求来进行选配，同时在极空APP的BMS控制页的复用端口切换选择CAN或者RS485，在使用主动均衡器的通信功能时用户可以根据自身的使用需求以及场景自行设置主动均衡器的地址以及通信协议，具体通信协议见极空主动均衡器通信协议文档。

The active equalizer supports the optional CAN/RS485 function, which CAN be selected according to your own requirements. At the same time, you can select CAN or RS485 for switching multiplexed ports on the BMS control page of the Extreme Space APP. When using the communication function of the active equalizer, you can set the address and communication protocol of the active equalizer according to your own requirements and scenarios. For specific communication protocols, see the communication protocol document of the Jikong active equalizer.

## 4. 主要参数 (Main parameter)

### 4.1. 基本参数(Basic parameter)

序号 (Serial number)	项目 (Project)	具体参数 (argument)	单位 (Unit)
1	供电电压(Supply voltage)	9-100	V
2	运行功耗(Operating power consumption)	≤1500	mW
3	工作温度(Operating temperature)	-30-70	°C
4	最大均衡电流(Maximum balancing current)	15	A
5	主动均衡器尺寸(Active equalizer size)	168.5*169.5*53	mm
6	成品重量(Finished weight)	1140	g

### 4.2. 默认参数(Default parameters)

序号 NUM	参数 PARA	三元默认 LI-ION	铁锂默认 LIFEPO4	钛酸锂默认 LTO	单位 (unit)
1	均衡起始电压 (balancing initial voltage)	3	3	2	V
2	最大均衡电流 (Maximum balancing current)	15	15	15	A
3	单体过充电压 (Unit overcharge voltage)	4.2	3.6	2.7	V
4	触发均衡压差 (Trigger balancing differential pressure)	0.01	0.01	0.01	V
5	设备地址 (Device address)	1	1	1	/

## 5. 接口定义(Interface definition)

### 5.1. 产品外形(Product Appearance)

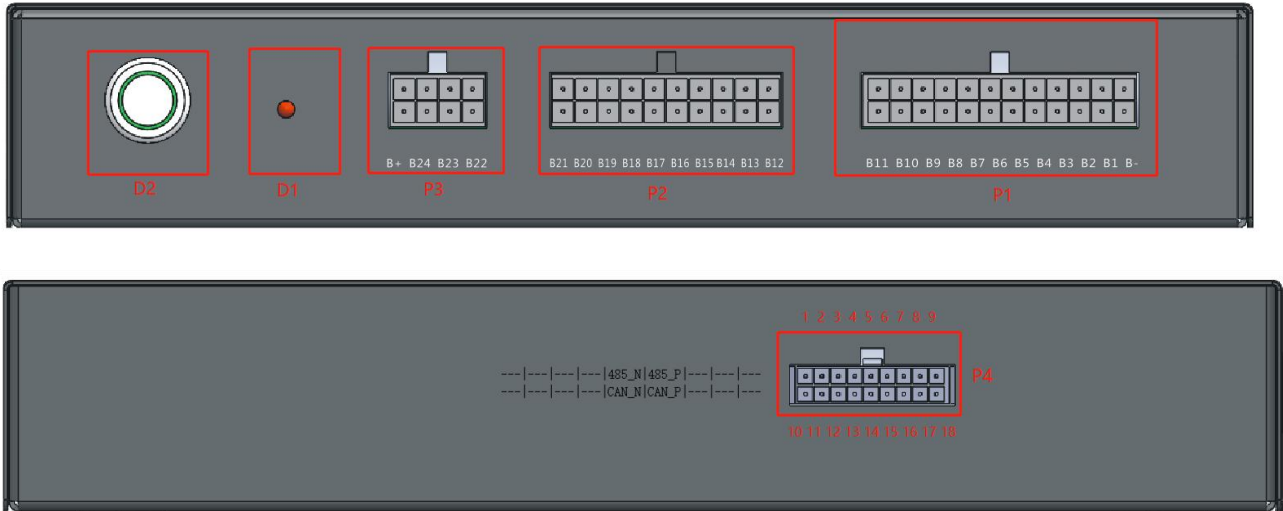

JK-B15A24S 连接器示意图

Schematic diagram of the JK-B15A24S connector

## 5.2. 产品连接器、LED 定义(Product connector, LED definition)

接口定义(Interface definition)

连接器 (coupler)	连接器型号 (Type of connector)	接口名称 (Interface name)	管脚号 (Pin number)	JK-B15A24S	
				名称 (Name)	定义 (definition)
P1	5569弯针 2*12P	均衡与采集接口 (Balance with Acquisition interface)	1	B-	电池总负极(Total negative battery)
			2	B1	第 1 串电池正极(The first battery positives)
			3	B2	第 2 串电池正极(The second battery positive)
			4	B3	第 3 串电池正极(The third battery positive)
			5	B4	第 4 串电池正极(The fourth battery positive)
			6	B5	第 5 串电池正极(The fourth battery positive)
			7	B6	第 6 串电池正极(The sixth battery positive)
			8	B7	第 7 串电池正极(The seventh battery positive)
			9	B8	第 8 串电池正极(The eighth battery positive)
			10	B9	第 9 串电池正极(The ninth battery positive)
			11	B10	第 10 串电池正极(The tenth battery positive)
			12	B11	第 11 串电池正极(The eleventh battery positive)
P2	5569弯针 2*10P	1	B12	第 12 串电池正极(The twelfth battery positive)	
		2	B13	第 13 串电池正极(The thirteenth battery positive)	
		3	B14	第 14 串电池正极(The fourteenth battery positive)	
		4	B15	第 15 串电池正极(The fifteenth battery positive)	
		5	B16	第 16 串电池正极(The sixteenth battery positive)	
		6	B17	第 17 串电池正极(The seventeenth battery positive)	
		7	B18	第 18 串电池正极(The eighteenth battery positive)	
		8	B19	第 19 串电池正极(The nineteenth battery positive)	
		9	B20	第 20 串电池正极(The twentieth battery positive)	
		10	B21	第 21 串电池正极(The twenty-first battery positive)	
P3	5569弯针 2*4P	1	B22	第 22 串电池正极(The twenty-second battery positive)	
		2	B23	第 23 串电池正极(The twenty-third battery positive)	
		3	B24	第 24 串电池正极(The twenty-fourth battery positive)	

			4	B+	均衡器电源，可以连接到3~24串电池的任意一节电池正极，亦可外接9-100V直流电源 (Equalizer power supply, can be connected to the positive pole of any 3~24 series of batteries, and can also be externally connected to a 9-100V DC power supply)
P4	MX3.0-2x9AWC	通讯接口 (Communication interface)	1	---	预留接口 (Reserved interface)
			2	---	预留接口 (Reserved interface)
			3	---	预留接口 (Reserved interface)
			4	---	预留接口 (Reserved interface)
			5	485-N	RS485-B信号负极 (RS485-B signal negative)
			6	485-P	RS485-A信号正极 (RS485-A signal positive)
			7	---	预留接口 (Reserved interface)
			8	---	预留接口 (Reserved interface)
			9	---	预留接口 (Reserved interface)
			10	---	预留接口 (Reserved interface)
			11	---	预留接口 (Reserved interface)
			12	---	预留接口 (Reserved interface)
			13	---	预留接口 (Reserved interface)
			14	CAN-N	CAN_L信号负极 (CAN_L signal negative)
			15	CAN-P	CAN_H信号正极

					(CAN_H signal positive)
			16	---	预留接口 (Reserved interface)
			17	---	预留接口 (Reserved interface)
			18	---	预留接口 (Reserved interface)
D1	蓝牙连接指示灯，当蓝牙连接上均衡器时指示灯常亮，断开连接时指示灯闪烁，均衡器是否正在均衡与指示灯无关。 (The D1 Bluetooth connection indicator light is always on when Bluetooth is connected to the equalizer, and flashes when disconnected. Whether the equalizer is being balanced is not related to the indicator light.)				
D2	均衡器自锁开关以及电源指示灯，当开关按下时均衡器开机同时指示灯常亮，再次按下开关使开关断开后均衡器关机，同时指示灯熄灭，均衡器是否正在均衡与指示灯无关。 (The self-locking switch and power indicator light of the equalizer will turn on when the switch is pressed, and the indicator light will remain on. Press the switch again to turn off the switch, and the equalizer will turn off. At the same time, the indicator light will turn off. Whether the equalizer is being balanced is not related to the indicator light.)				

### 5.3. 产品尺寸(Product size)

JK-B15A24S系列主动均衡器尺寸为 168.5mm×169.5mm×53mm如下图所示:

The size of JK-B15A24S series active equalizer is 168.5mm×169.5mm×53mm as shown in the following figure:

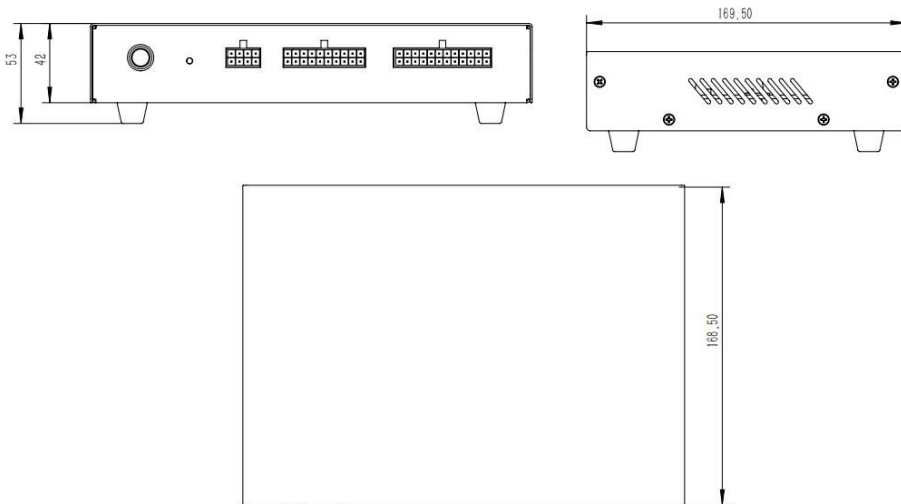

JK-B15A24S 外形尺寸

Dimensions of JK-B15A24S

## 6. 安装方法 (Installation method)

### 6.1. 单个均衡器安装(Single Equalizer Installation)

单个JK-B15A24S型均衡器适用于2-24串电池串联的电池组。但当电池组电压低于9V时，均衡器需提供外部直流9V~100V电源。

对于24串电池串联的电池组，安装接线方法如下图所示。

A single JK-B15A24S equalizer is suitable for battery packs with 2-24 series batteries connected in series. But when the voltage of the battery pack is below 9V, the equalizer needs to provide an external DC power supply of 9V~100V.

For a battery pack with 24 series of batteries connected in series, the installation and wiring method is shown in the following figure.

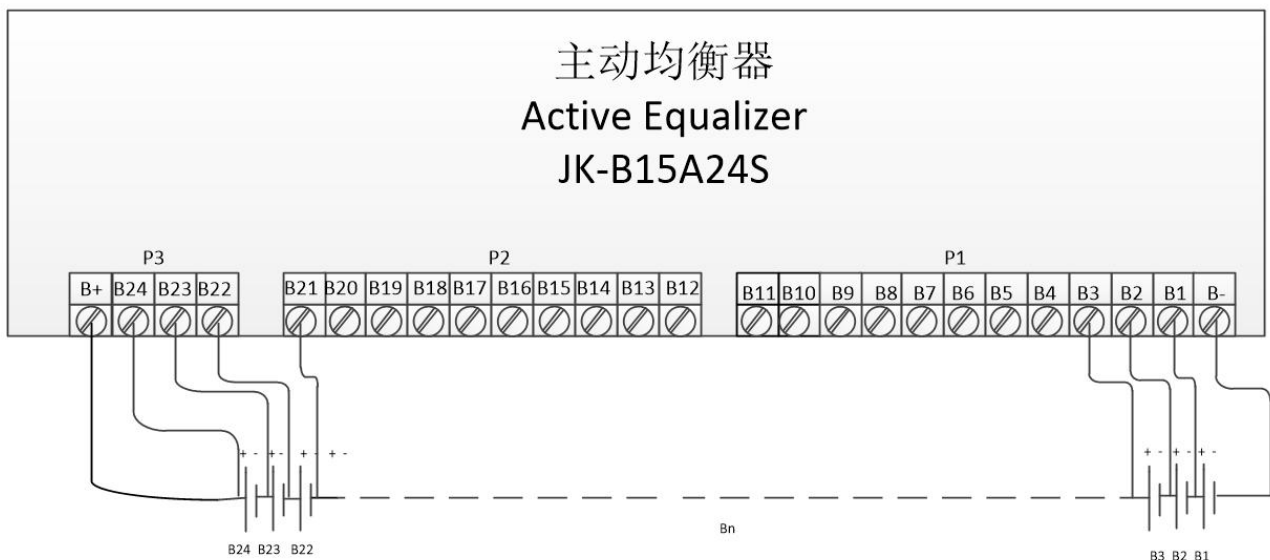

JK-B15A24S 接线图

JK-B15A24S wiring diagram

将均衡器应用于电压低于9V的电池组，安装接线方法如下图所示（图示以3串配合升压模块为例）。

Apply the equalizer to battery packs with a voltage below 9V, and the installation and wiring method is shown in the following figure (using a 3-series boost module as an example).

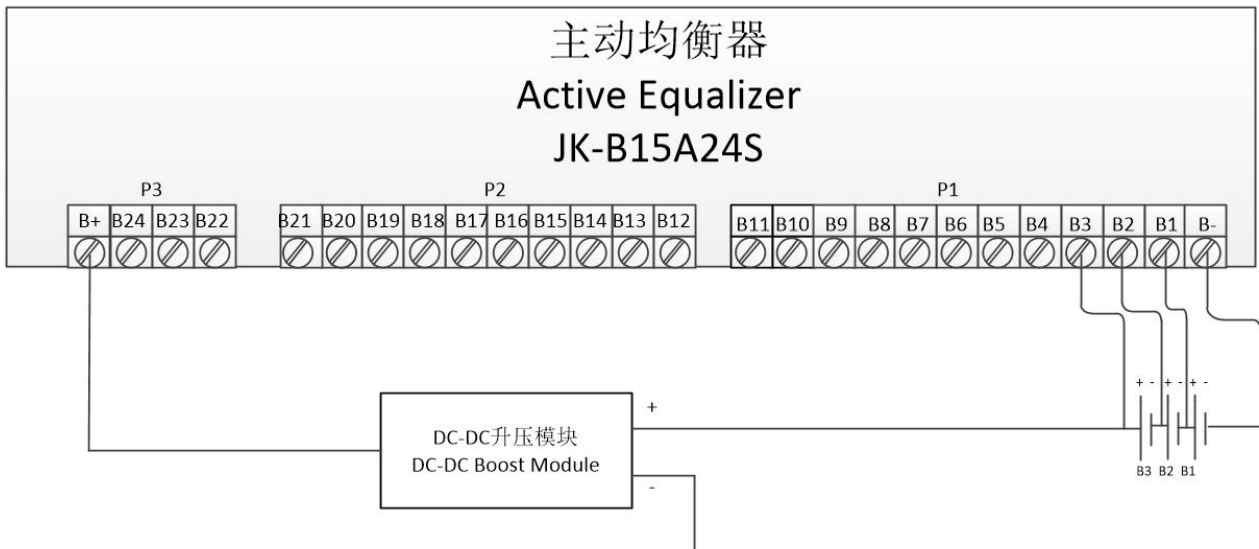

配合升压模块接线图

Wiring diagram for the booster module

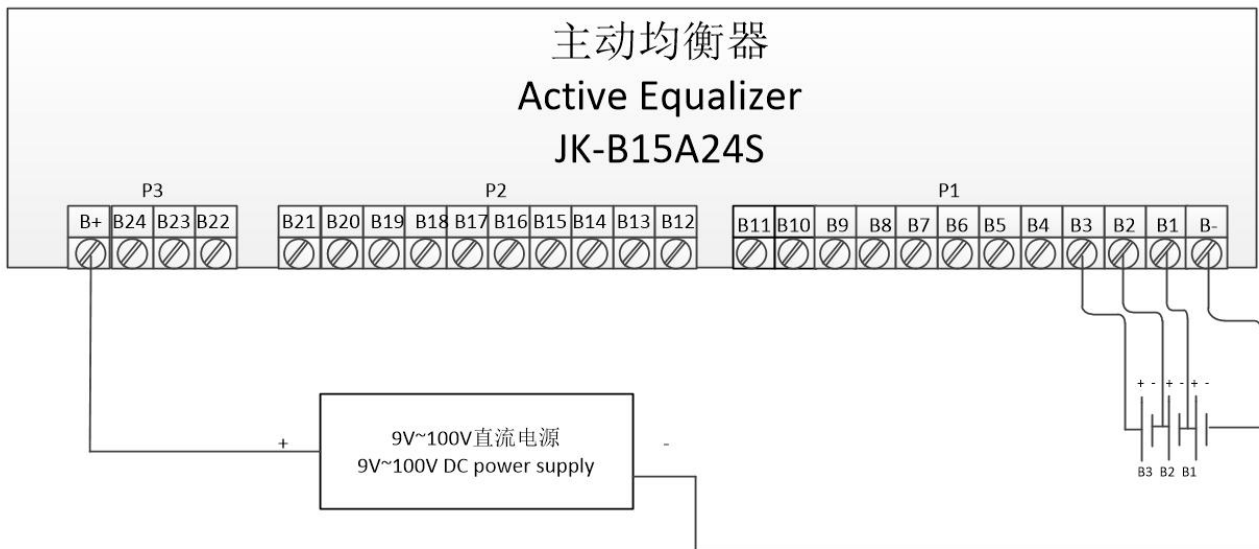

外部供电接线图

External power supply wiring diagram

## 6.2. 多个均衡器级联安装(Cascade installation of multiple equalizers)

JK-B15A24S型均衡器支持级联使用，这样可以将均衡器应用到24串以上的电池组。级联安装接线方法如下图所示。

The JK-B15A24S equalizer supports cascading use, which can be applied to battery packs with 24 or more strings. The cascading installation and wiring method is shown in the following figure.

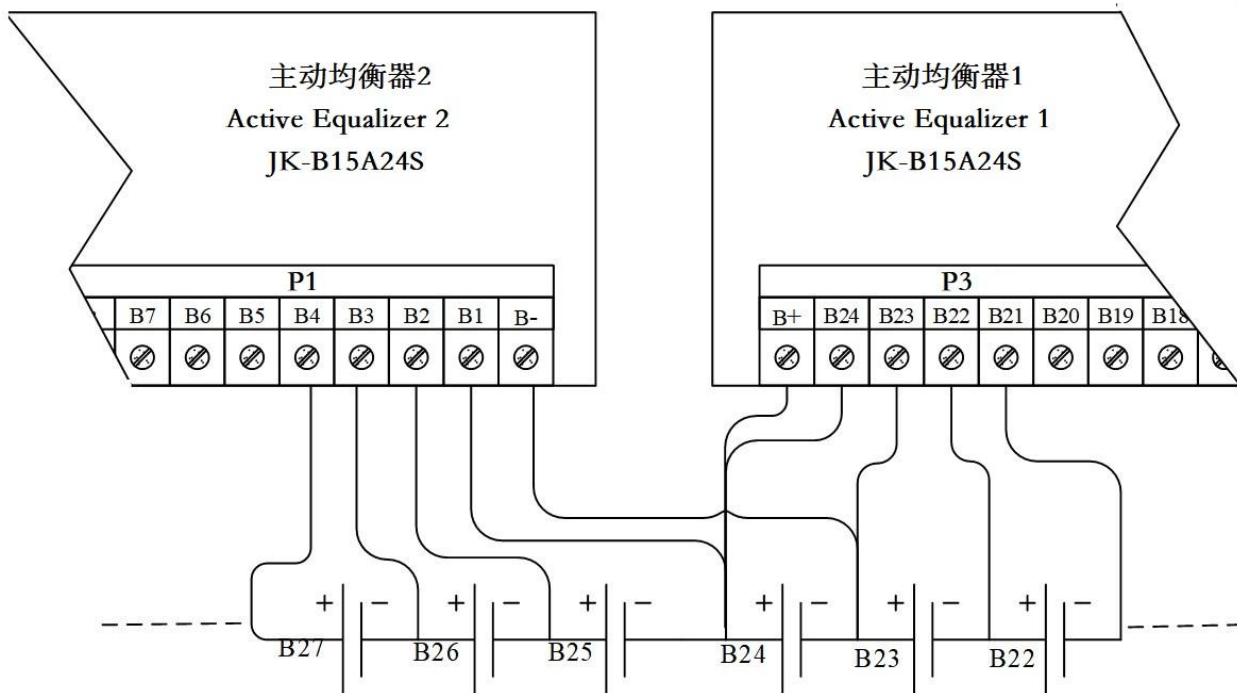

均衡器级联接线图  
 Equalizer Cascade Wiring Diagram

## 7. 设备使用说明(APP operation Instructions)

### 7.1. APP 安装 (APP installation)

通过扫描下图所示的二维码可以获取与产品配套的手机APP。

Mobile APP matching the product can be obtained by scanning the QR code shown in Figure . Android Version 7 minimum is required for the Android APP.



手机APP 链接二维码

Mobile APP link QR code

## 7.2. 设备激活(Device activation)

打开电源使用之前，请再次确认均衡线连接是否正常，给均衡器提供的电源是否在要求范围之内，检查均衡器是否已经稳妥的放置，确认无误后才可以接通均衡器电源，否则可能造成工作异常、甚至烧毁等严重后果。

确认上述操作无误以后，可以给均衡器上电。JK-B15A24S型均衡器有上电控制开关，当开关按下时均衡器开机同时指示灯常亮，再次按下开关使开关断开后均衡器关机，同时指示灯熄灭。

Before powering on the power supply, check whether the balance cable is properly connected, whether the power supply for the equalizer is within the required range, and whether the equalizer is properly placed before powering on the equalizer. Otherwise, serious consequences such as abnormal working or even burning may occur.

After confirming the preceding operations, power on the equalizer. Type JK-B15A24S equalizer has a power-on control switch. When the switch is pressed, the equalizer is turned on and the indicator is steady on. After the switch is turned off, the equalizer is turned off and the indicator is turned off.

## 7.3. 参数设置(Parameter setting)

详见“均衡器参数设置说明”。

Please refer to the "Equalizer Parameter Setting Instructions" for details.